

Ventose piatte (tonde) Serie VSCF

Novità

Ventose universali in NBR o Silicone.
Diametri da 1 a 100 mm con attacchi maschio e femmina da M3, M5,
G1/8, G1/4.



- » Profilo basso studiato per ridurre al minimo il volume d'aria da estrarre e garantire cicli di lavoro molto rapidi.
- » La struttura compatta contrasta efficacemente le forze trasversali e favorisce la stabilità del pezzo.
- » Movimento quasi nullo dei pezzi in fase di aspirazione.

Le ventose piatte Serie VSCF sono costituite da un nipplo e da una parte in gomma, forniti già assemblati. Entrambi i componenti possono essere ordinati singolarmente come pezzi di ricambio. Per diametri superiori a 60 mm nella gomma vulcanizzata è inserita una piastra di sostegno.

Situazioni generali di impiego sono, ad esempio, la movimentazione di pezzi con superfici di presa lisce o poco ondulate come lamiere, profili di estrusione, imballaggi in cartone, lastre di vetro, componenti in plastica, pannelli di legno, ecc.

Applicazioni:

- Movimentazione di pezzi con superfici di presa piane oppure ondulate come lamiere per carrozzerie, tubi, imballaggi in cartone, ecc.
- Versione in silicone per la manipolazione di pezzi ad alte temperature.

CARATTERISTICHE GENERALI

Descrizione	ventosa robusta e resistente costituita da ventosa VSCF e nipplo di raccordo
Costruzione	- nippoli e ventose sono consegnati non assemblati - a partire dal diametro 60 mm è inserita una piastra di irrigidimento nella gomma vulcanizzata
Manutenzione	è possibile la sostituzione dell' elemento morbido
Temperatura d'esercizio	versione in NBR: -30°C ÷ +120°C (per tempo breve <30 sec.); -10°C ÷ +70°C (a lungo termine) versione in SILICONE: -40°C ÷ +220°C (per tempo breve <30 sec.); -30°C ÷ +180°C (a lungo termine)

DATI TECNICI

Mod./Diametro	Forza d'aspirazione (N)*	Volume (cm ³)	Raggio di curvatura min. convesso (mm)	Diametro interno del tubo (mm)
VSCF-0010	0,03	0,000	2	2
VSCF-0015	0,08	0,001	2	2
VSCF-0020	0,15	0,002	2	2
VSCF-0030	0,30	0,003	8	2
VSCF-0040	0,40	0,005	8	2
VSCF-0050	0,90	0,013	8	2
VSCF-0060	1,40	0,020	8	2
VSCF-0080	2,40	0,044	8	2
VSCF-0100	4,00	0,070	13	2
VSCF-0120	5,00	0,120	13	2
VSCF-0150	9,00	0,220	20	4
VSCF-0180	13,00	0,370	20	4
VSCF-0200	15,00	0,500	20	4
VSCF-0250	23,00	0,900	25	4
VSCF-0300	34,00	1,600	35	4
VSCF-0350	46,00	2,400	40	4
VSCF-0400	61,00	3,800	50	4
VSCF-0500	95,00	7,100	75	4
VSCF-0600	140,00	12,700	75	6
VSCF-0700	198,00	18,000	100	6
VSCF-0800	254,00	25,100	100	6
VSCF-0900	328,00	34,300	150	6
VSCF-1000	402,00	46,400	200	6

ESEMPIO DI CODIFICA

VS	C	F	-	0010	N	-	M3	M
-----------	----------	----------	----------	-------------	----------	----------	-----------	----------

VS	SERIE: VS = ventosa
C	FORMA: C = tonda
F	VERSIONE: F = piatta
0010	DIAMETRI: 0010 = 1,0 mm 0015 = 1,5 mm 0020 = 2,5 mm 0030 = 3,0 mm 0040 = 4,0 mm 0050 = 5,0 mm 0060 = 6,0 mm 0080 = 8,0 mm 0090 = 9,0 mm 0100 = 10,0 mm 0120 = 12,0 mm 0150 = 15,0 mm 0180 = 18,0 mm 0200 = 20,0 mm 0250 = 25,0 mm 0300 = 30,0 mm 0350 = 35,0 mm 0400 = 40,0 mm 0500 = 50,0 mm 0600 = 60,0 mm 0700 = 70,0 mm 0800 = 80,0 mm 0900 = 90,0 mm 1000 = 100,0 mm
N	MATERIALI: N = NBR S = silicone
M3	DIMENSIONE FILETTATURA: M3 = M3 M5 = M5 1/8 = G1/8 1/4 = G1/4
M	TIPO FILETTATURA: M = maschio F = femmina

VENTOSE PIATTE SERIE VSCF

Ventosa VSCF-0010 a 0040 - filetto maschio



* = (N) ventosa in NBR - (S) ventosa in silicone
(N.B.: inserire nell'ordine la lettera desiderata)

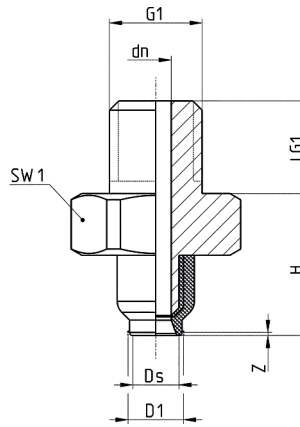

Mod.	G1	D1	dn	Ds	H	LG1	SW1	Z	Ventosa	Niplo
VSCF-0010 [*] -M3M	M3 M	1,1	1,0	1,0	4,6	3,0	5	0,1	VSCF-0010 [*]	NPS-A-M3-M
VSCF-0015 [*] -M3M	M3 M	1,7	1,0	1,5	4,6	3,0	5	0,1	VSCF-0015 [*]	NPS-A-M3-M
VSCF-0020 [*] -M3M	M3 M	2,4	1,0	2,0	5,5	3,0	5	0,2	VSCF-0020 [*]	NPS-A-M3-M
VSCF-0030 [*] -M3M	M3 M	3,7	1,0	3,0	5,5	3,0	5	0,3	VSCF-0030 [*]	NPS-A-M3-M
VSCF-0040 [*] -M3M	M3 M	4,7	1,0	4,0	5,5	3,0	5	0,4	VSCF-0040 [*]	NPS-A-M3-M

Ventosa VSCF-0050 a 0080 - filetto maschio



* = (N) ventosa in NBR - (S) ventosa in silicone
(N.B.: inserire nell'ordine la lettera desiderata)

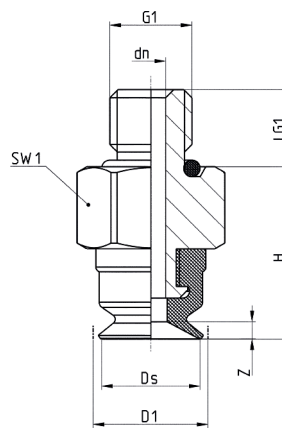

Mod.	G1	D1	dn	Ds	H	LG1	SW1	Z	Ventosa	Niplo
VSCF-0050 [*] -M5M	M5 M	5,7	1,8	5,0	10,5	4,7	8	0,5	VSCF-0050 [*]	NPS-C-M5-M
VSCF-0060 [*] -M5M	M5 M	6,8	1,8	6,0	10,5	4,7	8	0,6	VSCF-0060 [*]	NPS-C-M5-M
VSCF-0080 [*] -M5M	M5 M	8,4	1,8	8,0	10,5	4,7	8	0,8	VSCF-0080 [*]	NPS-C-M5-M

Ventosa VSCF-0050 a 0080 - filetto femmina



* = (N) ventosa in NBR - (S) ventosa in silicone
(N.B.: inserire nell'ordine la lettera desiderata)

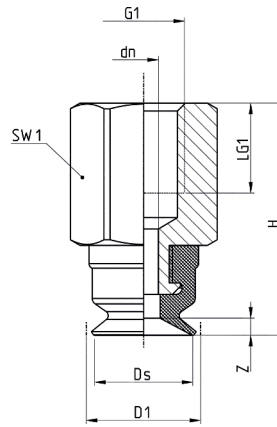

Mod.	G1	D1	dn	Ds	H	LG1	SW1	Z	Ventosa	Niplo
VSCF-0050 [*] -M5F	M5 F	5,7	1,8	5,0	14,2	5,5	8	0,5	VSCF-0050 [*]	NPS-C-M5-F
VSCF-0060 [*] -M5F	M5 F	6,8	1,8	6,0	14,2	5,5	8	0,6	VSCF-0060 [*]	NPS-C-M5-F
VSCF-0080 [*] -M5F	M5 F	8,4	1,8	8,0	14,2	5,5	8	0,8	VSCF-0080 [*]	NPS-C-M5-F

Ventosa VSCF-0100 a 0400 - filetto maschio



* = (N) ventosa in NBR - (S) ventosa in silicone
(N.B.: inserire nell'ordine la lettera desiderata)

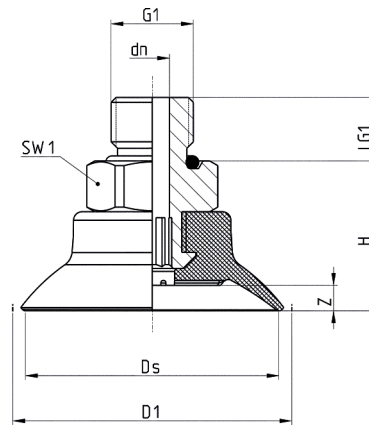

Mod.	G1	D1	dn	Ds	H	LG1	SW1	Z	Ventosa	Niplo
VSCF-0100 [*] -M5M	M5 M	11,2	1,8	10,0	13,4	4,7	8	1,0	VSCF-0100 [*]	NPS-B-M5-M
VSCF-0120 [*] -M5M	M5 M	13,2	1,8	12,0	13,6	4,7	8	1,2	VSCF-0120 [*]	NPS-B-M5-M
VSCF-0150 [*] -1/8M	G1/8 M	16,8	3,1	15,0	15,0	7,5	14	1,5	VSCF-0150 [*]	NPS-F-1/8-M
VSCF-0180 [*] -1/8M	G1/8 M	20,6	3,1	18,0	15,3	7,5	14	1,8	VSCF-0180 [*]	NPS-F-1/8-M
VSCF-0200 [*] -1/8M	G1/8 M	22,8	3,1	20,0	15,5	7,5	14	2,0	VSCF-0200 [*]	NPS-F-1/8-M
VSCF-0250 [*] -1/8M	G1/8 M	28,2	4,1	25,0	17,2	7,5	14	2,5	VSCF-0250 [*]	NPS-G-1/8-M
VSCF-0300 [*] -1/8M	G1/8 M	33,3	4,1	30,0	17,7	7,5	14	3,0	VSCF-0300 [*]	NPS-G-1/8-M
VSCF-0350 [*] -1/8M	G1/8 M	39,2	4,1	35,0	22,1	7,5	17	3,5	VSCF-0350 [*]	NPS-E-1/8-M
VSCF-0400 [*] -1/8M	G1/8 M	44,0	4,1	40,0	23,2	7,5	17	4,0	VSCF-0400 [*]	NPS-E-1/8-M

Ventosa VSCF-0100 a 0400 - filetto femmina

* = (N) ventosa in NBR - (S) ventosa in silicone
(N.B.: inserire nell'ordine la lettera desiderata)

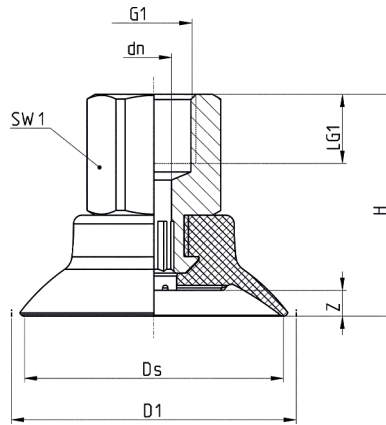

Mod.	G1	D1	dn	Ds	H	LG1	SW1	Z	Ventosa	Niplo
VSCF-0100 ^{*-} -M5F	M5 F	11,2	3,1	10,0	18,4	4,7	8	1,0	VSCF-0100*	NPS-B-M5-F
VSCF-0120 ^{*-} -M5F	M5 F	13,2	3,1	12,0	18,6	4,7	8	1,2	VSCF-0120*	NPS-B-M5-F
VSCF-0150 ^{*-} -1/8F	G1/8 F	16,8	3,1	15,0	23,0	8,0	14	1,5	VSCF-0150*	NPS-E-1/8-F
VSCF-0180 ^{*-} -1/8F	G1/8 F	20,6	3,1	18,0	23,3	8,0	14	1,8	VSCF-0180*	NPS-E-1/8-F
VSCF-0200 ^{*-} -1/8F	G1/8 F	22,8	3,1	20,0	23,5	8,0	14	2,0	VSCF 0200*	NPS-E-1/8-F
VSCF-0250 ^{*-} -1/8F	G1/8 F	28,2	4,1	25,0	25,2	8,0	14	2,5	VSCF 0250*	NPS-G-1/8-F
VSCF-0300 ^{*-} -1/8F	G1/8 F	33,3	4,1	30,0	25,7	8,0	14	3,0	VSCF 0300*	NPS-G-1/8-F
VSCF-0350 ^{*-} -1/8F	G1/8 F	39,2	6,1	35,0	28,9	8,0	17	3,5	VSCF 0350*	NPS-F-1/8-F
VSCF-0400 ^{*-} -1/8F	G1/8 F	44,0	6,1	40,0	30,0	8,0	17	4,0	VSCF 0400*	NPS-F-1/8-F

Ventosa VSCF-0500 a 1000 - filetto maschio

* = (N) ventosa in NBR - (S) ventosa in silicone
(N.B.: inserire nell'ordine la lettera desiderata)

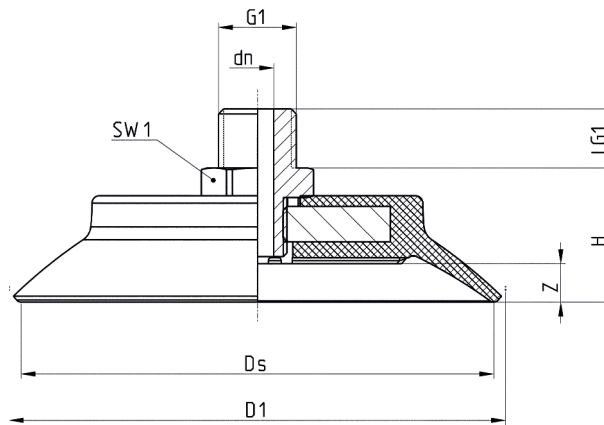

Mod.	G1	D1	dn	Ds	H	LG1	SW1	Z	Ventosa	Niplo
VSCF-0500 ^{*-} -1/8M	G1/8 M	54,3	4,1	50,0	24,2	7,5	17	5,0	VSCF-0500*	NPS-E-1/8-M
VSCF-0600 ^{*-} -1/4M	G1/4 M	66,4	5,1	60,0	22,0	10,0	17	5,5	VSCF-0600*	NPV-N-1/4-M
VSCF-0700 ^{*-} -1/4M	G1/4 M	77,2	5,1	70,0	22,5	10,0	17	6,0	VSCF-0700*	NPV-N-1/4-M
VSCF-0800 ^{*-} -1/4M	G1/4 M	87,1	5,1	80,0	23,0	10,0	17	6,5	VSCF-0800*	NPV-N-1/4-M
VSCF-0900 ^{*-} -1/4M	G1/4 M	98,1	5,1	90,0	23,2	10,0	17	7,0	VSCF-0900*	NPV-N-1/4-M
VSCF-1000 ^{*-} -1/4M	G1/4 M	108,0	5,1	100,0	24,0	10,0	17	7,5	VSCF-01000*	NPV-N-1/4-M

Ventosa VSCF-0500 a 1000 - filetto femmina

* = (N) ventosa in NBR - (S) ventosa in silicone
(N.B.: inserire nell'ordine la lettera desiderata)

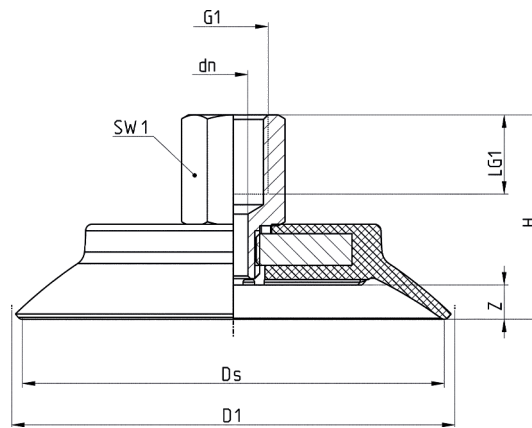

Mod.	G1	D1	dn	Ds	H	LG1	SW1	Z	Ventosa	Niplo
VSCF-0500 [*] -1/8F	G1/8 F	54,3	6,1	50,0	31,0	8,0	17	5,0	VSCF-0500 [*]	NPS-F-1/8-F
VSCF-0600 [*] -1/4F	G1/4 F	66,4	5,1	60,0	33,9	12,0	17	5,5	VSCF-0600 [*]	NPV-N-1/4-F
VSCF-0700 [*] -1/4F	G1/4 F	77,2	5,1	70,0	34,4	12,0	17	6,0	VSCF-0700 [*]	NPV-N-1/4-F
VSCF-0800 [*] -1/4F	G1/4 F	87,1	5,1	80,0	34,9	12,0	17	6,5	VSCF-0800 [*]	NPV-N-1/4-F
VSCF-0900 [*] -1/4F	G1/4 F	98,1	5,1	90,0	35,4	12,0	17	7,0	VSCF-0900 [*]	NPV-N-1/4-F
VSCF-1000 [*] -1/4F	G1/4 F	108,0	5,1	100,0	35,9	12,0	17	7,5	VSCF-01000 [*]	NPV-N-1/4-F